

2010.55.

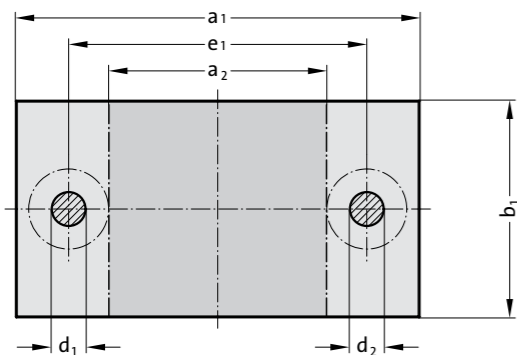

2010.57.

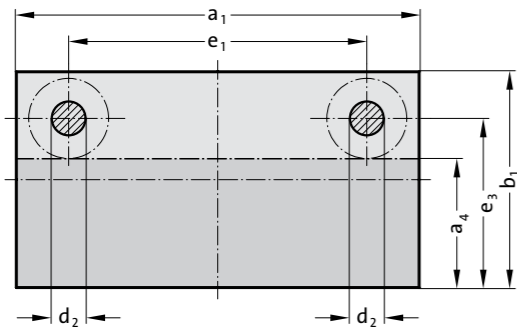

2010.59.

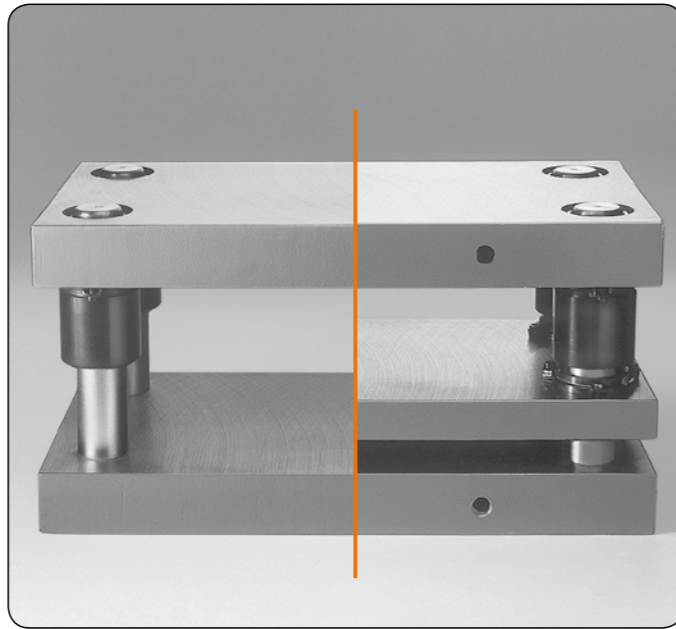
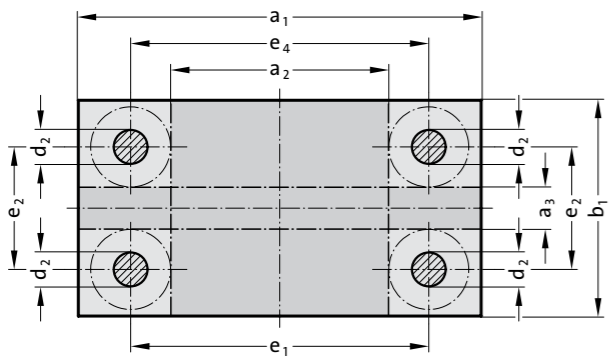

Ausführungen:

Mit eingepressten Führungssäulen 202.29.

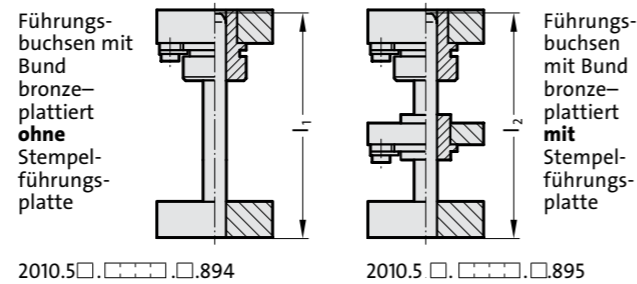

Mit Wechselführungssäulen 2021.29.***

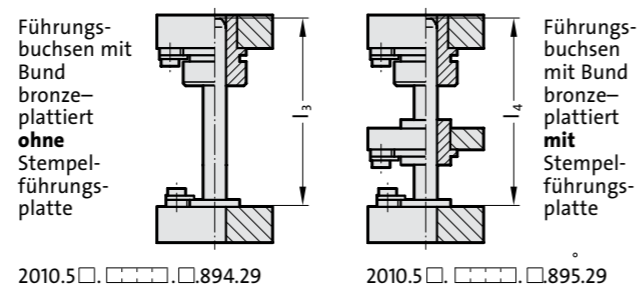

Beschreibung:

FIBRO-Stahlsäulengestelle 2010.5x werden mit bronzeplattierten Führungsbuchsen geliefert. Die Buchsen werden im Schiebeseitz gefügt und mit Haltestücken befestigt.

Ausführung:

Außenkonturen gefräst
Dickenflächen geschliffen

Hinweis:

*** Befestigung nur mit Haltestücken

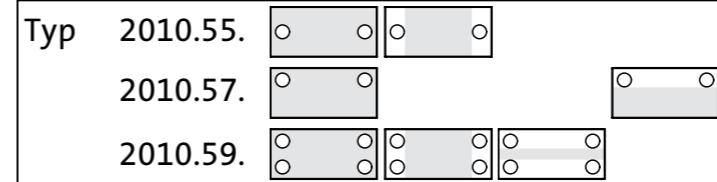

Bestell-Nr.

Typ	Größe	P.*	Ausführung	Ausführung***	Außenmaße		Arbeitsfläche(n)**		c1 ±2	c2 ±2	c3 ±2	c4	c5	d1/d2	l1/l2	l3/l4	D	e1	e2	e3	e4
2010.55.2512.1.					250 x 125	120 x 125	-	-	40	40	32	36	12	24/25	180/200	140/180	46	170	-	-	-
2010.55.2512.4.					250 x 125	120 x 125	-	-	32	32	32	36	12	24/25	180/200	140/180	46	170	-	-	-
2010.57.2520.1.	8	9	4		250 x 200	-	-	250 x 135	40	40	-	36	-	-/25	180/-	140/-	46	170	-	160	-
2010.57.2520.4.	8	9	4		250 x 200	-	-	250 x 135	32	32	-	36	-	-/25	180/-	140/-	46	170	-	160	-
2010.59.2520.4.					250 x 200	120 x 200	250 x 50	-	32	32	32	36	12	-/25	180/200	140/180	46	170	120	-	173
2010.59.2525.4.					250 x 250	120 x 250	250 x 100	-	32	32	32	36	12	-/25	180/200	140/180	46	170	170	-	173
2010.55.3116.1.					315 x 160	165 x 160	-	-	50	50	32	45	12	30/32	200/224	160/200	53	225	-	-	-
2010.55.3116.4.					315 x 160	165 x 160	-	-	40	40	32	45	12	30/32	200/224	160/200	53	225	-	-	-
2010.55.3120.4.					315 x 200	165 x 200	-	-	40	40	32	45	12	30/32	200/224	160/200	53	225	-	-	-
2010.57.3120.4.	8	9	4		315 x 200	-	-	315 x 125	40	40	-	45	-	-/32	200/-	160/-	53	225	-	155	-
2010.59.3120.4.					315 x 200	165 x 200	315 x 30	-	40	40	32	45	12	-/32	200/224	160/200	53	225	110	-	228
2010.57.3125.1.	8	9	4		315 x 250	-	-	315 x 175	50	50	-	45	-	-/32	200/-	160/-	53	225	-	205	-
2010.59.3125.1.					315 x 250	165 x 250	315 x 80	-	50	50	32	45	12	-/32	200/224	160/200	53	225	160	-	228
2010.59.3125.4.					315 x 250	165 x 250	315 x 80	-	40	40	32	45	12	-/32	200/224	160/200	53	225	160	-	228
2010.59.3131.1.					315 x 315	165 x 315	315 x 145	-	50	50	32	45	12	-/32	200/224	160/200	53	225	225	-	228
2010.55.4020.4.					400 x 200	250 x 200	-	-	40	40	32	45	12	30/32	200/224	160/200	53	310	-	-	-
2010.59.4020.4.					400 x 200	250 x 200	400 x 30	-	40	40	32	45	12	-/32	200/224	160/200	53	310	110	-	313
2010.55.4025.1.					400 x 250	250 x 250	-	-	50	50	32	45	12	30/32	200/224	160/200	53	310	-	-	-
2010.57.4025.1.	8	9	4		400 x 250	-	-	400 x 175	50	50	-	45	-	-/32	200/-	160/-	53	310	-	205	-
2010.59.4025.1.					400 x 250	250 x 250	400 x 80	-	50	50	32	45	12	-/32	200/224	160/200	53	310	160	-	313
2010.59.4025.4.					400 x 250	250 x 250	400 x 80	-	40	40	32	45	12	-/32	200/224	160/200	53	310	160	-	313
2010.57.4031.4.	8	9	4		400 x 315	-	-	400 x 240	40	40	-	45	-	-/32	200/-	160/-	53	310	-	270	-
2010.59.4031.1.					400 x 315	250 x 315	400 x 145	-	50	50	32	45	12	-/32	200/224	160/200	53	310	225	-	313
2010.59.4040.1.					400 x 400	250 x 400	400 x 230	-	50	50	32	45	12	-/32	200/224	160/200	53	310	310	-	313
2010.59.4040.4.					400 x 400	250 x 400	400 x 230	-	40	40	32	45	12	-/32	200/224	160/200	53	310	310	-	313
2010.55.5025.1.					500 x 250	325 x 250	-	-	50	50	32	45	15	38/40	200/224	160/200	63	400	-	-	-
2010.59.5025.1.					500 x 250	325 x 250	500 x 75	-	50	50	32	45	15	-/40	200/224	160/200	63	400	150	-	403
2010.59.5025.4.					500 x 250	325 x 250	500 x 75	-	40	40	32	45	15	-/40	200/224	160/200	63	400	150	-	403
2010.55.5031.1.					500 x 315	325 x 315	-	-	50	50	32	45	15	38/40	200/224	160/200	63	400	-	-	-
2010.59.5031.1.					500 x 315	325 x 315	500 x 140	-	50	50	32	45	15	-/40	200/224	160/200	63	400	215	-	403
2010.59.5040.1.					500 x 400	325 x 400	500 x 225	-	50	50	32	45	15	-/40	200/224	160/200	63	400	300	-	403
2010.59.5050.1.					500 x 500	325 x 500	500 x 325	-	50	50	32	45	15	-/40	200/224	160/200	63	400	400	-	403

*Plattendicken-Kombination

**Lage der Haltestücke für die Buchsen ist nicht abhängig von der Arbeitsfläche!

***mit Wechselführungssäulen 2021.29.

Lieferung am nächsten Tag!

Bestell-Beispiel:

Gestell-Typ (Außenmaße a, x b, = 400 x 250; c, = c, = 50)	=	2010.55.4025.1.
Ausführung mit Stempelführungsplatte	=	895.
mit Wechselführungssäulen 2021.29.	=	29
Bestell-Nummer	=	2010.55.4025.1.895.29

Bestell-Beispiel:

Gestell-Typ (Außenmaße a, x b, = 400 x 250; c, = c, = 50)	=	2010.55.4025.1.
Ausführung mit Stempelführungsplatte	=	895
Bestell-Nummer	=	2010.55.4025.1.895